



### *RJ45 Crimping Tool*

P/N	Description	Std Pkg Qty
6102-01002	Crimping for RJ12(6P) and RJ45(8P) plug,suitable for solid and stranded wire used.	1



### *UTP Cables Stripper*

P/N	Description	Std Pkg Qty
6101-01001	Turning 3 circles to extract the jacket of UTP cable, Dual function of stripper and 110 tool	1



### *110 Punch Down Tool*

P/N	Description	Std Pkg Qty
6103-01001	For seating wires into connecting blocks, and cuts off wire end after termination	1



### *5 Pairs 110 Impact Tool*

P/N	Description	Std Pkg Qty
6103-04001	Seating wire onto terminal block and cut off wire end after termination, Used for 110 type I.D.C. blocks	1



### *Insertion Tool*

P/N	Description	Std Pkg Qty
6107-00006	Insertion tool with sensor for modules	1





**LAN Maintenance Tool Kit**

P/N	Description	Std Pkg Qty
6106-01003	<ul style="list-style-type: none"> <li>→ 8P/6P crimping tool x 1</li> <li>→ Cable cutter x 1</li> <li>→ Cable stripper x 1</li> <li>→ Punch down tool x 1</li> <li>→ Boot x 20</li> <li>→ 6P4C plug x 30</li> <li>→ 8P8C plug x 30</li> <li>→ UTP Twin tester x 1</li> </ul>	1

**Professional Fiber Tool Kit**

P/N	Description	Std Pkg Qty
<p><b>NEW</b></p> <p>6106-02003</p>	<ul style="list-style-type: none"> <li>→ 200x Microscope x 1</li> <li>→ Light pen x 1</li> <li>→ Syringe x 1</li> <li>→ Carbide scribe x 1</li> <li>→ Stripper x 1</li> <li>→ A/B fast epoxy glue x 1</li> <li>→ ST &amp; SC polish disc x 1</li> <li>→ Glass working pad x 1</li> <li>→ Wipe paper x 3</li> <li>→ Kevlar cutter x 1</li> <li>→ Crimp tool x 1</li> <li>→ Cleanser x 1</li> <li>→ Rubber working pad x 1</li> <li>→ 6um/1um/0.05um diamond polish film x 1</li> </ul>	1



## Twin Tester

The DINTEK twin tester provides instant identification of most common voice and data cabling problems including shorts, opens, reversals, and incorrect polarity.

The master and remote units separate for end-to-end testing of installed cabling or work separately as 2 patch cord test unit. Both pieces simply snap and lock together when not in use, making it easy to carry and store. Designed to fit neatly into a toolbox or pocket, the UTP tester has a convenient 'ring' feature for attaching to a belt or frame. The UTP tester should be used to check each channel from the station device to the system.

- Innovative 2-in-1 design features modular jacks for testing USOC and 568A/B cabling systems
- Accurately verifies the continuity and sequence of 1-,2-,3-, and 4-pair voice and data channels
- Continuously-sequencing LED display provides a diagnostic readout that immediately detects shorts, opens, reversals, and mis-wires at a glance
- Simply snap and lock master and remote units together when not in use
- Ergonomically designed hand-held unit is light weight, rugged, and impact-resistant
- 9 volt alkaline battery excluded
- Carry case included

### Technical specification:

- Materials: ABS
- Distance: 1,000m (3,280ft)
- Power requirements: 9 volt battery(standard or alkaline)
- Weight: 240g (9 oz.)
- Built-in interface: USOC,EIA 568B
- Contact specification: 30 u" gold over nickel



Caution  
Do not use on live circuits

P/N	Description	Std Ctn Qty
6201-03002	Twin Tester with Carry Bag	8



**Function 1:**  
**Patch Cable Test**

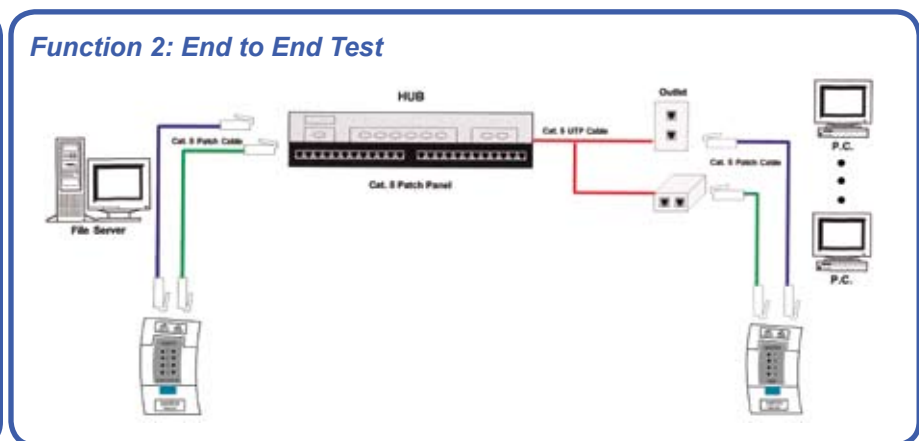

### Tester Result:

Master	Remote	Tester Result
LED on GREEN	LED on GREEN	Good channel
LED on GREEN	LED on RED	Reversal
LED on RED	LED off	Short with in pair
2LEDs on GREEN/RED	2LEDs on GREEN/RED	Short between pairs
LED off	LED off	Open